



Design and Fabrication of Multipurpose Agriculture Vehicle

Madhavan P, Anil Kumar, Sivakumar R

^{1,2,3}Department of Mechanical Engineering, PERI Institute of Technology, Chennai..

Article Information

Received : 08 Jan 2023
Revised : 21 Feb 2023
Accepted : 07Mar 2023
Published : 18 Mar 2023

Abstract— The main aim of the project is to develop multipurpose agricultural vehicle, for performing major agricultural operations like ploughing, seeding, harvesting. The modification includes fabricating a vehicle which is small, compact in size. The project is about a machine design which makes cultivation much simpler. The design of the chassis of the vehicle is made in such a way that it is suitable for the operations. The design for automatic seed modified the currently available plough tool in such a way that it with stand the load. The harvester (cutter) is designed and working by scotch yoke mechanism.

Corresponding Author:
Madhavan P

Keywords: *Ploughing, Seed sowing, Harvester, Cutter, Chassis, Scotch yoke mechanism, Cultivation, Agriculture, Operations, Design.*

Copyright © 2023: Madhavan P, Anil Kumar, Sivakumar R. This is an open access distribution, and reproduction in any medium, provided Access article distributed under the Creative Commons Attribution License the original work is properly cited License, which permits unrestricted use.

Citation: Madhavan P, Anil Kumar, Sivakumar R. “Design and Fabrication of Multipurpose Agriculture Vehicle, “Journal of Science, Computing and Engineering Research, 6(3), 38-45, 2023.

I. INTRODUCTION

Agriculture is the cultivation of animals, plants and fungi used to sustain and enhance human life agriculture was the key development in the rise of sedentary human civilization. The study of agriculture is known as agricultural science. The history of agriculture dates back thousands of years, and its development has been driven and defined by greatly different climates, cultures, and technologies. Modern agronomy, plants breeding, agrochemicals such as pesticides and fertilizers, and technological developments have in many cases sharply increased yields from cultivation, but at the same time have caused widespread ecological damage. Agricultural food production and water management are increasingly becoming global issues. Mechanized agriculture is the process of using agriculture machinery to mechanize the work of agriculture, greatly increasing farm worker productivity in modern times, and powered machinery has replaced many farm jobs formerly carried out by manual labour or by working animals such as oxen, horses and mules.

The entire history of agriculture contains many examples of the use of tools, such as the hoe and the plough. But the ongoing integration of machines since the industrial revolution has allowed farming to become much less labour intensive current mechanized agriculture includes the use of tractors, trucks, combine harvesters, countless types of farm implements, airplanes and helicopters and other vehicles. Precision agriculture even uses computers in conjunction satellite imagery and satellite navigation to increase yields. Mechanization was one of the large factors responsible for urbanization and industrial economies. Besides improving production efficiency, mechanization encourages large scale

production and sometimes can improve the quality farm produce on the other hand it can displace unskilled farm labour and can cause environmental degradation especially if it is applied short-sightedly rather than holistically.

II. SCOPE AND OBJECTIVE

A. Scope of the Project

- The seed sowing mechanism is modified into simple mechanism
- The multipurpose agriculture vehicle is designed for small farmers in future
- The project will become an example for future works

B. Objective of the Project

- The primary objective is to develop a harvester which is simple and cost effective
- The reduction of cost of the Ploughing tool
- The life of the Ploughing tool is increase

III. PROPOSED WORK METHODOLOGY

A. Chassis of the Vehicle

The choice of material for the vehicle is the first and most important factor for automotive design. There is variety of materials that can be used in automotive body and chassis. The most important criteria that a material should meet are lightweight, economic effectiveness, safety, recyclability, and life cycle consideration. Some of these criteria are the result of legislation and regulation. The material for the frame and chassis is steel. The main factors for selecting material specially for body is wide

variety of characteristics such as thermal, chemical and mechanical resistant which are ease for manufacturing and durability. In the frame only the main supporting structures such as engine of the vehicle, the harvester and ploughing tool are mounted. It support the tool static and dynamic load of the vehicle.

B. Frame Design

The design is made which is suitable supporting all the operations. The frame is made for a compact size vehicle.

Fig. 1 2D – Design of frame

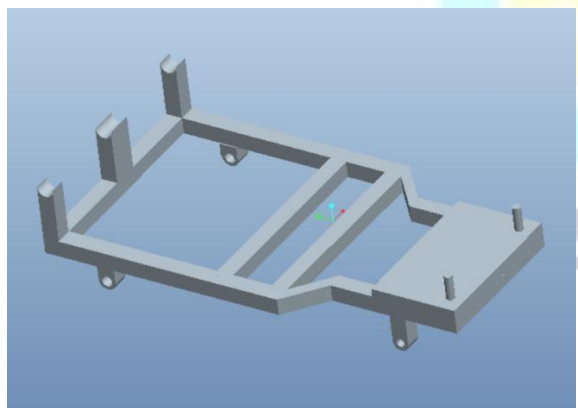
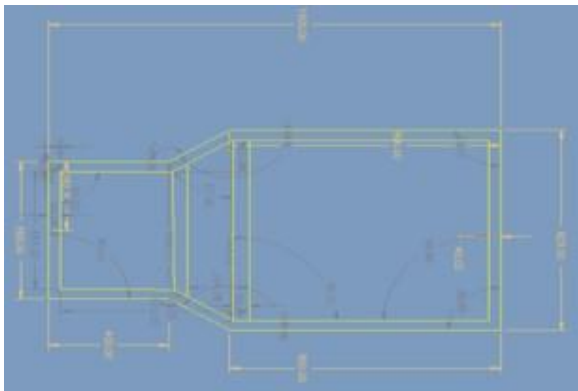

Design of frame

C. Ploughing Tool

Concept of the Tool

The Ploughing tool is designed in the way that it wouldn't break due to the sudden encounter of rocks and roots present in the soil. The faults in the current tool is changed and modified. The designed new tool is durable and affordable and can be used in all kinds of geographical region.

Design of the Proposed Tool

The life of the tool is increased by replacing the only the tip of the tool. The sharpness of the tool is remains constant for significantly longer period of time. The efficiency and the effectiveness of the tool is increased. The optimum weight of the tool is obtained. The breakage of the tool is reduced by using high speed steel in the tip. The material used for plough tool is High Speed Steel.

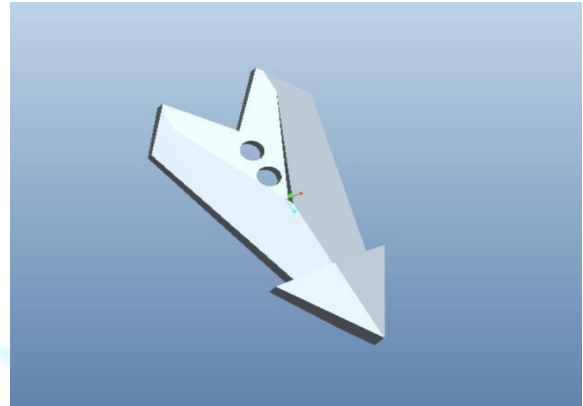

Fig. 3 Ploughing tool design

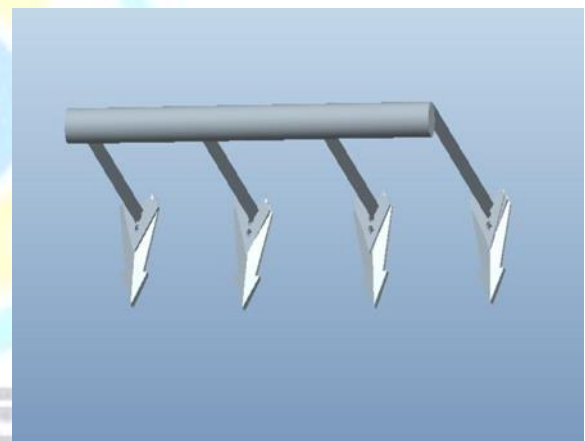

Fig.4 Plougher 3D-design

D. Seed Sowing Machine

The existing seed sowing machine is too cost. It is abundantly available in India. The cost of the machine is going to be reduced by introducing the common seed storage place in the machine. A motor drive mechanism is used Major Components in the Proposed Sowing Machine The proposed sowing machine consist of the following components

E. Hopper

It is an arrangement to store the seeds. The shape of the hopper is rectangular box so the wastage of the seed can be avoided. It is made up of galvanized iron 20G sheet it reduces the weight of the hopper.

F
ig. 2
3D –

Sliding Plate

The base of the hopper consists of a sliding plate with holes spacing in equal distance. The sliding plate reciprocates to and fro above the base of the hopper. It is made up of mild steel plate.

F. Harvester

The harvester design is based on the design of brush cutter. The cutter is more robust and stronger. The denser vegetation can be cleared with it easily.

G. Mechanism and Design

The scotch yoke mechanism is used in the harvester design. It is also known as slotted link mechanism. It converts rotational motion into linear motion. The reciprocation part is directly coupled with the sliding yoke. The components in the harvester are frame plate, scotch, yoke, supporting rods and blades. One blade is fixed stationary and the other one is fixed to the moving rod.

H. Scotch Yoke Mechanism

The Scotch yoke mechanism is a reciprocating motion mechanism, converting the linear motion of a slider into rotational motion, or vice versa. The piston or other reciprocating part is directly coupled to a sliding yoke with a slot that engages a pin on the rotating part. In many internal combustion engines, linear motion is converted into rotational motion by means of a crankshaft, a piston and a rod that connects them. The Scotch yoke is considered to be a more efficient means of producing the rotational motion as it spends more time at the high point of its rotation than a piston and it has fewer parts. The location of the piston versus time is a sine wave of constant amplitude, and constant frequency given a constant rotational speed. The reciprocating motion as discussed in construction part above. The power is supplied to the Dc motor, shaft and crank attached to the shaft start rotating. As the crank rotates the pin slides inside the yoke and also moves the yoke forward. When the crank rotates through in clockwise direction the yoke will get a displacement in the forward direction. The maximum displacement will be equal to the length of the crank. When the crank completes the next of rotation the yoke comes back to its initial position. For the next of rotation, yoke moves in the backward direction.

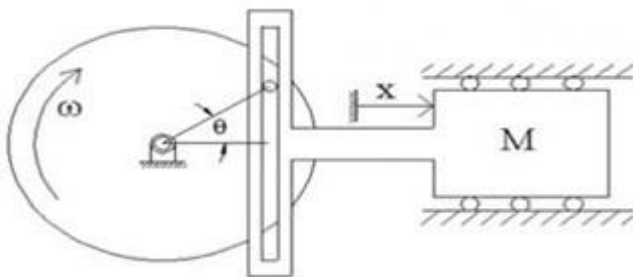

Fig. 5 Scotch Yoke Mechanism

When the crank completes a full rotation, the yoke moves back to the initial position. For a complete rotation of crank the yoke moves through a length equal to double the length of the crank. The displacement of the yoke can be controlled by varying the length of the crank.

Fig. 6 Harvester Design

The 3D design for the harvester is given below and it consist of the following parts

- 1) Scotch
- 2) Yoke
- 3) Frame plate
- 4) Blade

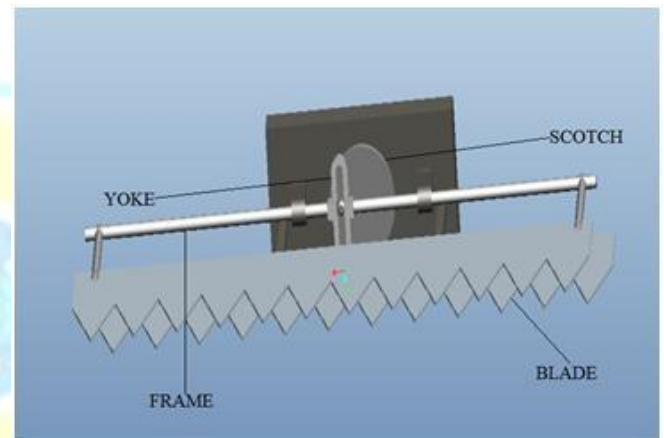

Fig. 6 Harvester Design

I. Design of the Assembled Components

The design of the assembled components includes the ploughing tool, harvester using scotch yoke mechanism and seed sowing machine which are mounted on the vehicle frame.



Fig. 7 3D Design of the Multipurpose Agriculture Vehicle

IV. FABRICATION AND ASSEMBLY

A. Chassis of the Vehicle

The chassis of the vehicle is made of iron square section of 40*40 mm dimension. The section is cut and welded according to the given design dimension.



Fig. 8 Chassis of the Vehicle

B. Fabrication of the Ploughing Tool and Frame

The plough tool is fabricated using high speed steel. The tool is machined by cutting and grinding operations. The tool is fixed to the plough frame and various supports were given in the frame for fixture of the plough frame in the vehicle. A separate hook and lever is attachment is given so that it prevent the motion of the plough in outward direction. The tool and the frame are welded using metal arc welding.



Fig. 9 Plough Tool with Frame



Fig. 10 Plough Mounting

C. Fabrication of Seed Sowing Machine

This machine consists of hopper, a sliding plate and a motor. The hopper (Fig 4.4) is made through sheet metal. In the sliding plate (Fig 4.5) equally distant four holes is made and a slot is given for the movement of to and fro motion which is connected to the dc geared motor.



Fig. 11 Hopper



Fig. 12 Sliding Plate

D. Fabrication of Harvester (Cutter)

The cutter blade is fabricated, one is static blade and another one is movable. The frame for fixing the blade and for the scotch yoke mechanism is made. For scotch yoke mechanism, rotation scotch and a sliding yoke is made. The motor is attached to the rotating scotch. The speed of the motor is 800 rpm. The dimension of the blade is 720x110 mm. The collection box dimension is 550x230x200 mm.

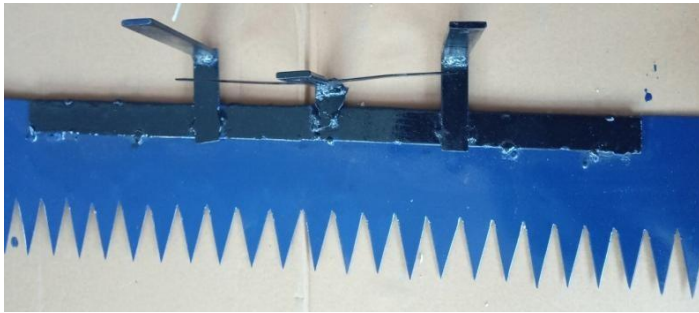

Fig. 14 Blade with Frame



Fig. 15 Fixed blade



Fig. 16 Cutter Assembly

E. Engine Specification

The engine used for purpose of prime mover is pulsar engine. Displacement : 149 cc

Engine Type : 4-stroke, Air cooled, Single cylinder, DTSi engine

Fig. 17 Engine

Max. Power : 14 PS @ 8000 rpm Max. Torque : 13.4 Nm @ 6000 rpm Fuel Type : Petrol

Final Drive (rear): Chain drive



Selection of Tyre

Tractor tyre specification is a key element in achieving fuel efficiency. Factors that need to be considered include tread, diameter, width, rim size, load indexes, and typical operating speeds. Larger tyres spread the weight and enable operation at lower and at a wider range of pressures.

For Rear wheel, Rim : 430 mm Tyre : 700 mm

For front wheel, Rim : 350 mm Tyre : 510 mm

The rim type is steel and the tube is used in the tyres.



Fig. 18 Tyre with Rim

F. Front and Rear Axle

The front axle is fixed to the chassis of the vehicle. It is made up of circular rod tapered in the ends are attached to the front wheel hub. In the hub, the support for steering system link rod is provided. The wheel is rotated around the fixed front axle. The rear wheel axle is a shaft of length 1100 mm and the diameter of the shaft is 35mm. The shaft is connected to the hub of the rear wheel. vehicle.



Fig. 19 Front Axle

The sprocket for chain drive connection is attached in the rear axle. The axle rod supports on the bearing attached to the chassis of the vehicle.



Fig. 20 Rear Axle

G. Steering System

The steering system used is manual steering system with rack and pinion setup. It is considered to be entirely adequate for smaller vehicle. It is tight, fast and accurate in maintain steering control. There are many types of steering system is available of which rack and pinion type is selected. The steering link is connected to the front wheel hub. A link rod is connected to the rack and pinion setup. On the link rod the steering wheel is fixed. By rotating the wheel the circular motion is converted to linear motion which is transferred to the front axle. So it helps to turn the wheel on the desired direction.

H. Assembled View of Vehicle

The separately fabricated components are assembled in the vehicle frame. The harvester is attached to the front. The plough tool is attached with the clamp at the backside of the frame. The seed sowing machine is attached in respective place.



Fig. 21 Front View of Assembled vehicle



Fig. 22 Side View of Assembled Vehicle

V. DESIGN ANALYSIS AND TESTING

A. Design Calculation for Shaft

Power of the engine, $P = 10.297 \text{ kW}$

Displacement = 149 cc

Power, $P = 2\pi NT/60$

$10297 = (2 * 3.14 * 8000 * T)/60$

Torque, $T = 13.4 \text{ Nm} = 13400 \text{ N-mm}$

Now T is the maximum torque among all shaft, checking the shaft for failure

$T = (\pi/16) * 135 * d^3 / 13400 = (3.14/16) * d^3$

$D = 7.96 = 8 \text{ mm}$

But in this project, the diameter of the shaft is 35mm. So the design is safe.

B. Bending Stress Calculation of the Axle Shaft

Consider the weight of 1500 N is acting on the shaft, Induced stress, $\sigma = M/Z$

Moment, $M = (WL)/4$ Where, W = load; L = Length $M = (1500 * 1100)/4$

$M = 412500 \text{ N/mm}$

Section modulus, $Z = (\pi/16) * d^3 / 32 = (3.14/16) * 35^3$

$Z = 8414.21 \text{ mm}^3$

$\sigma = (412500/8414.21)$

$\sigma = 49.02 \text{ N/mm}^2$

Therefore, Induced stress < Allowed stress

$49.02 \text{ N/mm}^2 < 270 \text{ N/mm}^2$

(Hence the design is safe).

C. Calculation for Cutter

$P = 2\pi NT/60 \text{ watts}$

$P = \text{Power}$ $N = \text{Speed of motor}$ $T = \text{Torque}$ Then, $P = V * I$

$V =$ Voltage $I =$ Current Power input to the motor, $P_{in} = I * V$

$$P_{in} = 8 * 12$$

$$P_{in} = 96W \quad (1)$$

Power output from motor to shaft,

$$P_{out} = T * \omega \quad (2)$$

Motor Efficiency,

From equation 1 & 2, $E = P_{out} / P_{in} 0.36 = [T * (2\pi * N/60)] / 96$

$$T * (2\pi * 65/60) = 34.56 \quad T = 5.0773Nm$$

Here, the power, torque and speed generated on the motor shaft is transmitted wholly to the crank of the crank and slotted lever mechanism. The cutting velocity of the blade can be determined by the relation between lever speed and the stroke length of the blade.

Here, $\beta =$ Cutting Angle $\alpha =$ Return Angle

In ACB2, $\cos(\alpha/2) = CB2/AC = 0.0750.08807 \quad \alpha = 63.23$

Also, $\beta = 360 - \alpha \quad \beta = 360 - 63.23$

$$\beta = 296.77$$

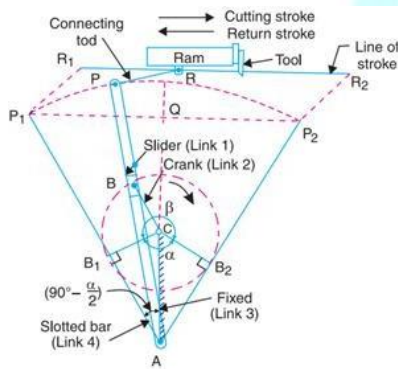

Fig. 23 Scotch Yoke Mechanism

Quick Return Ratio or Time ratio, $\beta/\alpha = 296.77/63.23$

$$\beta/\alpha = 4.6635$$

Stroke length,

$$R1R2 = P1P2 = 2P1Q$$

Here, $P1Q = AP1 * \sin(90 - \alpha/2) \quad P1Q = 176.14 * \sin(90 - 63.23/2) \quad P1Q = 150mm$

Therefore, $R1R2 = 2 * 150 \quad R1R2 = 300mm \quad 31$

Now, Cutting speed of the blade, $V_c = (s * N_s/1000) (1+1/QRR)$ Where, $S =$ Stroke Length $N_s =$ Number of strokes per minute. $QRR =$ Quick Return Ratio

$$V_c = 0.300 * 251000 (1+14.9635)$$

$$V_c = 0.0075 * 1.2015$$

$$V_c = 0.00901103 \text{ m/min} \quad V_c = 1.5018 \times 10^{-4} \text{ m/s}$$

$$V_c = 1.5018 \times 10^{-4} \times 3600 \times 103$$

$$V_c = 540.648 \text{ mm/hr}$$

Now, Volume of grass cut per hour is given by, $V_g = V_c \times \text{Clearance Area}$

$$V_g = 540.648 \times 3 \times 800$$

$$V_g = 1297555.2 \text{ mm}^3/\text{hr}$$

$$V_g = 0.0012975552 \times 109 \text{ m}^3/\text{hr}$$

D. Calculation for Plough

Depth of cut= 5 cm

Speed of the tool= 2.5 km/hr = 41.66 m/hr No. of tool= 4

Feed rate= $Rpm \times N \times CL \quad FR = 41.66 \times 4 \times 0.05$

Feed rate, $FR = 8.332 \text{ m}^2/\text{min}$

E. Tool Life Calculation

From Taylor's tool life equation, $vT_n = C$

Where, $v =$ velocity

$T =$ tool life $C, n =$ Taylor coefficient For HSS, $n = 0.2$

$$V = 41.6 \text{ m/min} \quad 41.6 \times T^n = 100$$

$$T = 2.4 \times 10^{20} \text{ cycles}$$

For mild steel, $T = 2.4 \times 10^{10} \text{ cycles}$

F. Calculation for seed sowing:

Speed of the motor= 30 rpm Row spacing= 22 cm

Seed sowing time= 2 sec/per seed No. of openings = 4

Seed dropping per minute = $30 \times 4 = 120 \text{ seeds}$

If the speed of the wheel is 42 m/min, then for 42 meter 120 seed is dropped.

VI. BILL OF MATERIAL

Table1

Sl.No	Items	Cost
1	Iron, Steel, Sheet Metal	3,500
2	Engine	5,000
3	Tyre, Rim, Hub	7,000
4	Steering System	1,500
5	Machine Rent	5,000
6	Tools Purchased	1,500
7	Motor	1,000
8	Wiring Kit	700
9	Battery	1,200
	Total	26,400

VII. RESULT AND DISCUSSION

Table 2

Sl.no	Description	Result
1	Cutting speed of the blade	540.648 mm/hr
2	Area of cutting	0.7 m ²
3	Feed rate of plough	8.332 m ³ /min
4	Tool life for Plough tool	2.4x10 ²⁰ cycles
5	Seed dropping rate at 42 m/min	120

The plough tool life is compared with the commonly used material and the result obtained is the life of the tool is more efficient. The operations like ploughing, seed sowing and harvesting is done in the same vehicle, so the cost is reduced. The existing seed sowing machine is weighs more and complex working metering mechanism. But in this sowing machine, the weight is reduced and the working method is simple by connection a separate motor.

VIII. CONCLUSION

This project entitled Design and Fabrication of Multipurpose Agriculture Vehicle is successfully completed and the results obtained are satisfactory. It will be easier for the people who are going to take the project for the further modifications. It very useful for small scale farmers. The cost can be reduced by using this type of vehicle. The agricultural operations is made easier. The reduction in cost of the plough tool is done and the life is also increased. The seed sowing machine is made with simple mechanism. The cutter blade is made working by scotch yoke mechanism.

IX. FUTURE WORK

More operations can be included to the vehicle like pesticide sprayer, tiller and many other machines for various operation. The engine of the vehicle can be replaced with diesel engine. The tyre can be changed according to the type of the land. The plough tool tip arrangement is made separately, so in case of breakage the tip of the tool is alone changed. The collection system of the harvester can be made more efficiently.

REFERENCES

[1]. M. Kamaraj, Akshay Kumar Chhabria, Kartick Kumar, Nishant Kumar, "Design and Fabrication of Multi-Purpose Farming ToolsEquipped", International Journal of Innovative Research in Advanced Engineering (IJIRAE) ISSN: 2349-2163 Issue 05, Volume 4 (May 2017).
 [2]. M.V.Achutha, Sharath Chandra, Nataraj.G.K. ,“Concept Design and Analysis of Multipurpose FarmEquipment”,

International Journal of Innovative Research in Advanced Engineering (IJIRAE) ISSN: 2349-2763 Issue 02, Volume 3 (February 2016).
 [3]. Girish and Srihari, “Design and fabrication of multipurpose farm equipment”, International Journal for Scientific Research & Development| Vol. 4, Issue 06, 2015.
 [4]. Suraj V Upadhyaya, VijayaVittalaGowda G, Poojith M B, Vikranth, “A Review of Agricultural Seed Sowing”, International Journal of Innovative Research in Science, Engineering and Technology.
 [5]. Dr. C.N.Sakhale, Prof. S.N.Waghmare, “Multipurpose Farm Machine”,International Research Journal of Engineering and Technology (IRJET) e-ISSN: 2395 -0056 Volume: 03 Issue: 09 | Sep-2016 www.irjet.net p-ISSN: 2395-0072.
 [6]. V.M. Martin Vimal1, A. Madesh, S.Karthick, A.Kannan, “Design and fabrication of multipurpose sowing machine”, International Journal for Scientific Research & Development| Vol. 5, Issue 04, 2015.
 [7]. Tejas P Phadnis*, Apoorv N Mulay, Anand S Bhujbal and Gautam J Narwade, “Design of Agricultural Ploughing Tool”, International Journal of Emerging Technology and Advanced Engineering.
 [8]. J. R. Arunkumar, S. Velmurugan, B. Chinnaiyah, G. Charulatha, M. Ramkumar Prabhu et al., "Logistic regression with elliptical curve cryptography to establish secure iot," Computer Systems Science and Engineering, vol. 45, no.3, pp. 2635–2645, 2023.
 [9]. Aravind C, Shivashankar V, Vikas R, VikasV, “Design & Development of Mini Paddy Harvester”, International Journal for Scientific Research & Development| Vol. 3, Issue 05, 2015.
 [10]. Ms. TruptiA.Shinde , Dr. Jayashree. S. Awati, “Design and Development of Automatic Seed Sowing Machine”, International Journal for Scientific Research & Development.
 [11]. P.Vijay, K.V.N.Rakesh, B.Varun, “Design of a Multi-Purpose Seed Sower Cum Plougher”, International Journal of Emerging Technology and Advanced Engineering, Website: www.ijetae.com (ISSN 2250-2459, ISO 9001:2008 Certified Journal, Volume 3, Issue 4, April 2013).
 [12]. Prathima Chilukuri , J.R. Arun Kumar , R. Anusuya , M. Ramkumar Prabhu. “Auto Encoders and Decoders Techniques of Convolutional Neural Network Approach for Image Denoising In Deep Learning” Journal of Pharmaceutical Negative Results, 13(4), 1036–1040. <https://doi.org/10.47750/pnr.2022.13.04.142> ,November 4, 2022.
 [13]. RautMadhuri, Prof. P.S.Gorane, Pawar Ganesh, Patil Shubham, PatilNikhi, “Multipurpose Seed Sowing Machine”, International Journal of Advanced Technology in Engineering, volume 4, Issue 12, 2016
 [14]. Ms. TruptiA.Shinde Dr. Jayashree. S. Awati, Design and Development of Automatic Seed Sowing Machine, International Journal of Electronics and Communication Engineering - (ICRTESTM) - Special Issue – April 2017.
 [15]. AishwaryaChaudhari, Nikita Gaikwad, ShitalKolekar, NehaKothule, “Sensor Based Multipurpose Agricultural Cutter”, International Research Journal of Engineering and Technology (IRJET) Volume: 03 Issue: 05, May-2016.
 [16]. Prathima, C. H., Anusuya, R., & Prabhu, M. R. K. (2022). Comprehensive Design Analysis of Digital Marketing in Agriculture Sector. International Journal of Early Childhood Special Education, 14(5), 2022.

- [17].ChinmayBandiwadekar, AjinkyaKamble, VivekGarala, ZuberShaikh, “Design & Development of Chaff Cutting Machine”, International Journal for Scientific Research & Development, Vol. 4, Issue 02, 2016.
- [18].SaurabA.Bobde, RohitV.Gajapuri, “A Review on Solar Operated Agri Cutter”, International Journal for Innovative Research in Science & Technology, Volume 3, Issue 09 , February 2017.
- [19].Meselhy, A. A, “Design and Performance Evaluation of Circular Chisel Plow in Calcareous Soil”, International Journal of Emerging Technology and Advanced Engineering, Volume 4, Issue 11, November 2014.
- [20].P.Amrutesh, B.Sagar, B.Venu, “Solar Grass Cutter With Linear Blades By Using Scotch Yoke Mechanism”, International Journal of Engineering Research and Applications, Vol. 4, Issue 9(Version 3), September 2014.

